

This drawing is the property of Garner Industries. It is issued in confidence on the condition that it is to be returned on request and that it is not to be copied or reproduced in any way, or used in the manufacture of the subject matter thereof without the written consent of Garner Industries.

DIMENSIONS ARE IN INCHES UNLESS NOTED OTHERWISE



Division of Garner Industries / 7201 North 98th Street / Lincoln, NE 68507
(402) 434-9102 / fax (402) 434-9144 \ www.binmaster.com

AVAILABLE PROBE ASS'Y OPTIONS		AVAILABLE FITTING OPTIONS	
PROBE NO.	ASS'Y P/N	FITTING NO.	ASS'Y P/N
P27	530-0198	FA	175-0083
P34	530-0200	FB	175-0082
P62	530-0202	FC	175-0093
P29	530-0268		
P30	530-0234		
P28	530-0267		
P71	530-0199		
P56	530-0266		
P57	530-0265		
P40	530-0228		
P39	530-0227		

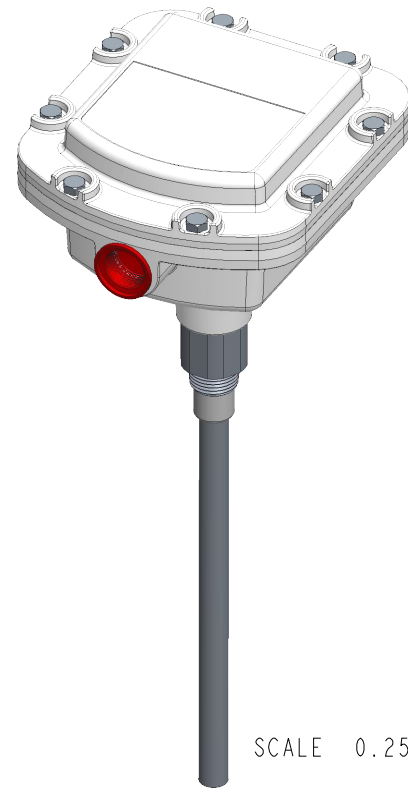

SCALE 0.250

PROBE ASS'Y AVAILABLE OPTIONS		FA & FB	FC	
PROBE NO.	ASS'Y P/N	a	a	b
P27	530-0198	1.75	1.25	10
P34	530-0200	1.75	1.25	4-96
P62	530-0202	1.75	1.25	6
P29	530-0268	1.75	1.25	18
P30	530-0234	1.75	1.25	24
P28	530-0267	1.75	1.25	4
P71	530-0199	1.75	1.25	3
P56	530-0266	1.75	1.25	36
P57	530-0265	1.75	1.25	30
P40	530-0228	1.75	1.25	4-96
P39	530-0227	1.75	1.25	10

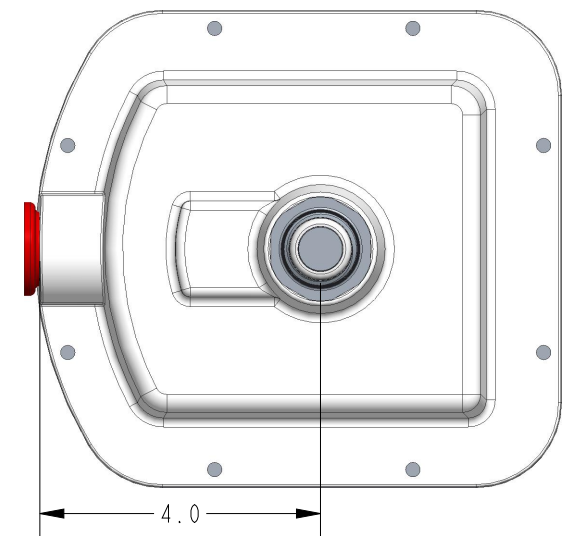
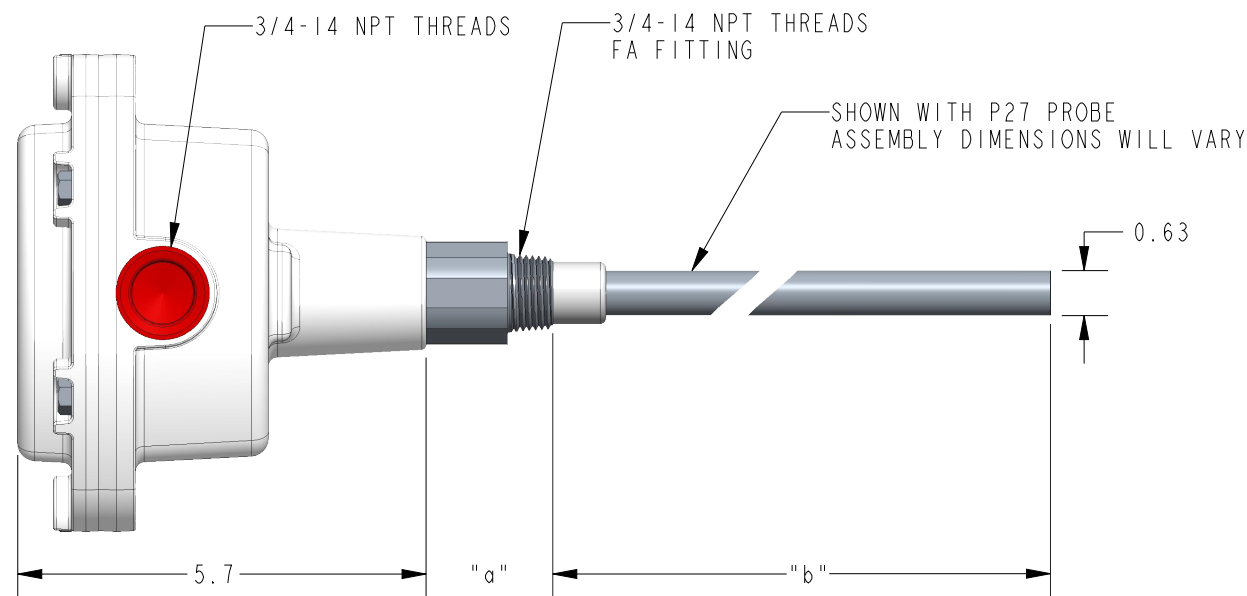
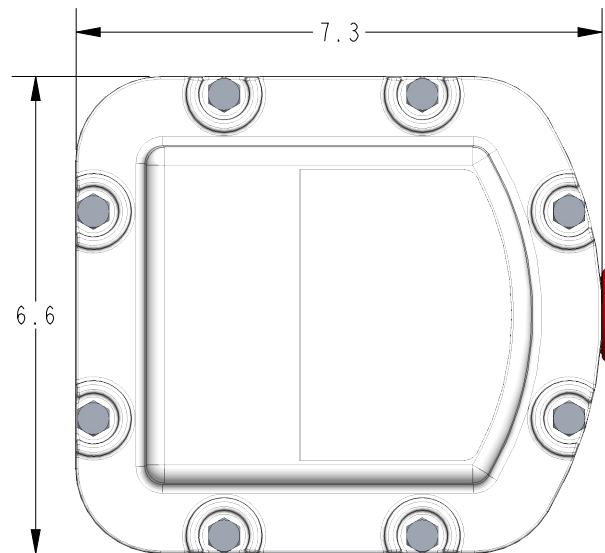

SCALE 0.375

TITLE: MTG DIM, DUST DETECT 1000

Model No.: DD1000-230VAC

P/N: 730-5011

Model No.: DD1000-115VAC

P/N: 730-5010

DWG No.: 418-0056

REVISION A

PAGE 1 OF 1